



Type: Class 150~ 1500 Forged Steel Trunnion Mounted Ball Valve

Features:

Size: 2" ~20"

Pressure: Class 150~ 1500

Material:ASTM A105N,A182 F304,A182 F316,A182 F304L,A182 F316L

Design: ANSI B16.34,API 608,API 6D,BS5351

Structure type: two pcs, three pcs, full bore, reduced bore, lever, gear, pneumatic, electric.

Ends: ANSI B16.5, ANSI B16.25

Predominance:

Bolted cover or welded cover,three-piece Body,fixed Ball

Full or Reduced bore,Blowout Proof Stem

Fire safe and Anti static

Dual seat with injection and drain & outlet

Details:

Class 150~ 1500 Forged Steel Trunnion Mounted Ball Valve

Installation dimension drawing

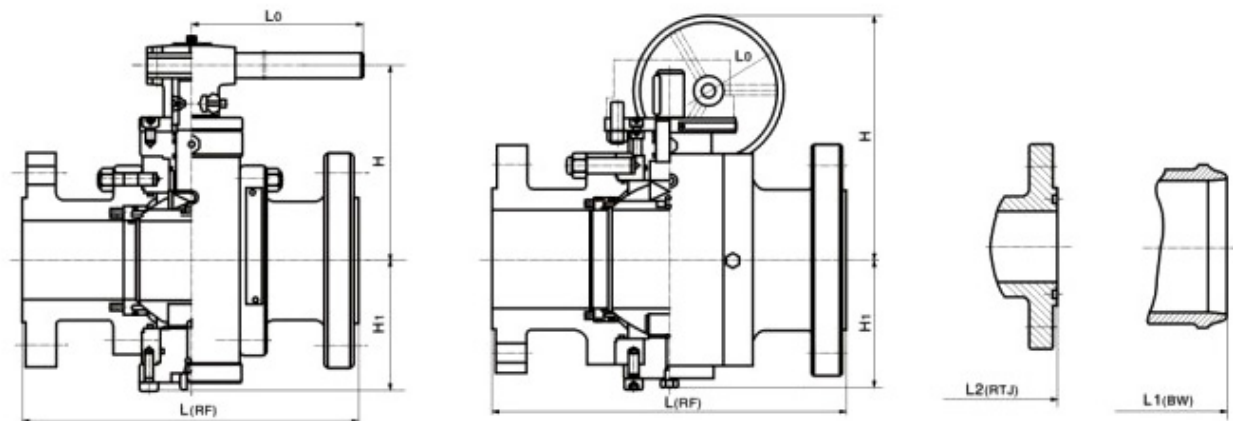

Material List of Class 150~1500 Forged Steel Trunnion Mounted Ball Valve

Standard material specifications					
Part name	Material List				
Body	A105	A182 F304	A182 F316	A182 F304L	A182 F316L
Body cap	A105	A182 F304	A182 F316	A182 F304L	A182 F316L
Ball	A105+Nip	A182 F304	A182 F316	A182 F304L	A182 F316L
Stem	A105+Nip	A182 F304	A182 F316	A182 F304L	A182 F316L
Seat	A105+Nip	A182 F304	A182 F316	A182 F304L	A182 F316L
Seat ring	PTFE/RPTFE/NYLON				
Fixed turnnion	A105+Nip	A182 F304	A182 F316	A182 F304L	A182 F316L
O-ring	VITON	VITON	VITON	VITON	VITON
Contact spring	17-7PH/In conel	In conel	In conel	In conel	In conel
Cover bolt	A193 B7	A193 B8	A193 B8M	A193 B8M	A193 B8M
Cover nut	A194 2H	A194 8	A194 8M	A194 8M	A194 8M
Bearing	SF-1	SF-1	SF-1	SF-1	SF-1

Class 150 Forged Steel Trunnion Mounted Ball Valve

Dimensions & weights												
Class 150												
Size	inch	2	3	4	6	8	10	12	14	16	18	20
L(RTJ)	mm	178	203	229	394	457	533	610	686	762	864	914
H	mm	153	195	213	500	568	605	662	725	770	970	935
H1	mm	139	178	191	220	289	318	382	430	470	489	528
L0	mm	400	600	850	400*	400*	400*	400*	800*	800*	600*	500*
Weight	mm	30	50	90	203	289	450	588	676	864	764	911

Class 300 Forged Steel Trunnion Mounted Ball Valve

Dimensions & weights												
Class 300												
Size	inch	2	3	4	6	8	10	12	14	16	18	20
L	mm	216	283	305	403	502	568	648	762	838	914	911
L(RTJ)	mm	232	299	321	419	518	584	664	778	854	930	1010
H	mm	153	195	213	500	569	605	662	725	770	970	935
H1	mm	139	178	191	220	289	318	382	430	470	489	528
L0	mm	600	1250	1300	400*	400*	400*	400*	800*	800*	600*	500
Weight	mm	30	50	90	203	289	450	588	676	864	764	911

Class 600 Forged Steel Trunnion Mounted Ball Valve

Dimensions & weights												
Class 600												
Size	inch	2	3	4	6	8	10	12	14	16	18	20
L	mm	292	356	432	559	660	787	838	889	991	1092	1194

L(RTJ)	mm	295	359	435	562	663	790	841	892	994	1095	1200
H	mm	153	195	213	500	569	645	702	750	815	970	1065
H1	mm	119	145	180	220	289	318	382	430	470	489	561
L0	mm	600	1250	1300	400*	400*	457*	457*	800*	800*	600*	600*
Weight	mm	32	64	122	267	521	773	1118	1700	1970	1218	1646

Class 900 Forged Steel Trunnion Mounted Ball Valve

Dimensions & weights												
Class 900												
Size	inch	2	3	4	6	8	10	12	14	16	18	20
L	mm	368	381	457	610	737	838	965	1029	1130	1210	1321
L(RTJ)	mm	372	384	460	613	780	841	968	1038	1140	1232	1334
H	mm	162	205	239	591	700	700	820	950	990	1030	1200
H1	mm	119	145	180	213	254	327	368	442	483	523	615
L0	mm	600	1250	1300	450*	600*	750*	750*	600*	600*	600*	600*
Weight	mm	48	78	138	275	547	847	1224	1676	2083	2694	3515

Class 1500 Forged Steel Trunnion Mounted Ball Valve

Dimensions & weights												
Class 1500												
Size	inch	2	3	4	6	8	10	12	14	16	18	20
L	mm	368	470	546	705	832	991	1130	1257	1384	1537	1664
L(RTJ)	mm	372	473	549	711	841	1000	1146	1276	1407	1559	1686
H	mm	197	254	291	655	660	735	860	950	1065	1235	1275
H1	mm	119	145	180	213	278	384	440	442	483	576	615
L0	mm	600	1250	1300	760*	450*	450*	660*	600*	750*	750*	750*
Weight	mm	55	97	162	328	668	936	1408	1861	2392	3220	4491